

PACKING YOUR MARC FOR SHIPMENT

How to package your MūL Technologies MARC system for shipment if original packaging was not retained.

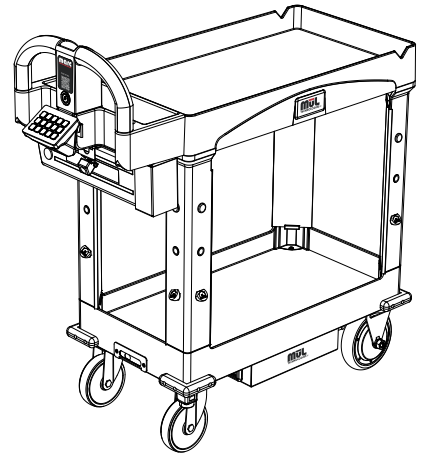

1. Remove battery from cart.
2. Packaging cart standing up:
 - a. Place cart on pallet and secure cart using ratchet straps or similar.
 - b. DO NOT place packaging materials in contact with the lidars to avoid damage due to contacting laser unit.
 - c. Remove EZ-Go Navigation panel from handle by unplugging and lifting upward. Wrap in bubble wrap, and secure in cart tray.
3. Packaging cart on its side:
 - a. Place foam or other protective material between the cart and packaging solutions to ensure side sensors are not damaged.
 - b. Place foam or other protective material between side of RCP and packaging solution so that the RCP is not damaged.
 - c. DO NOT place packaging materials in contact with the lidars to avoid damage due to contacting laser unit.
 - d. Remove EZ-Go Navigation panel from handle by unplugging and lifting upward. Wrap in bubble wrap or similar material and secure.
 - e. Cart should be tied down to packaging solutions using ratchet straps or similar to keep it in place during transit. Be sure not to overtighten.

Reach out to your salesperson or support@multechnologies.com if you have any questions or concerns.

Please note that the lithium batteries cannot be shipped with your unit – they require a separate hazardous material shipment process. Contact us for more information on that process if needed.